



## **Uso terapeutico della canapa: presente e futuro prossimo**

*Giovanni Appendino  
Dipartimento di Scienze del  
Farmaco  
Università del Piemonte  
Orientale, Novara  
appendino@pharm.unipmn.it*

## Vox populi 2.0: La mediatizzazione della canapa

**LAZAMPA.it**

**Cannabis terapeutica anche per cani e gatti, il Nevada ci prova**



## *La canapa è originaria dell'Asia Centrale*



大麻



## *La canapa: un'eccellenza agricola italiana*



*The best hemp in the world  
is grown in the Romagna of  
Italy*

*J. H. Maiden (Agricultural  
Gazette of New South  
Wales, 1983)*

Nel 1919, l'esportazione italiana di canapa rappresentava il 50% di tutte le esportazioni di canapa del mondo

Dopo la proibizione del 1982, nel 1998 furono ri-introdotte varietà francesi

# Canapa: una pianta "multiuso"

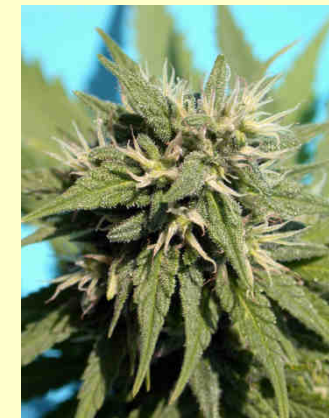
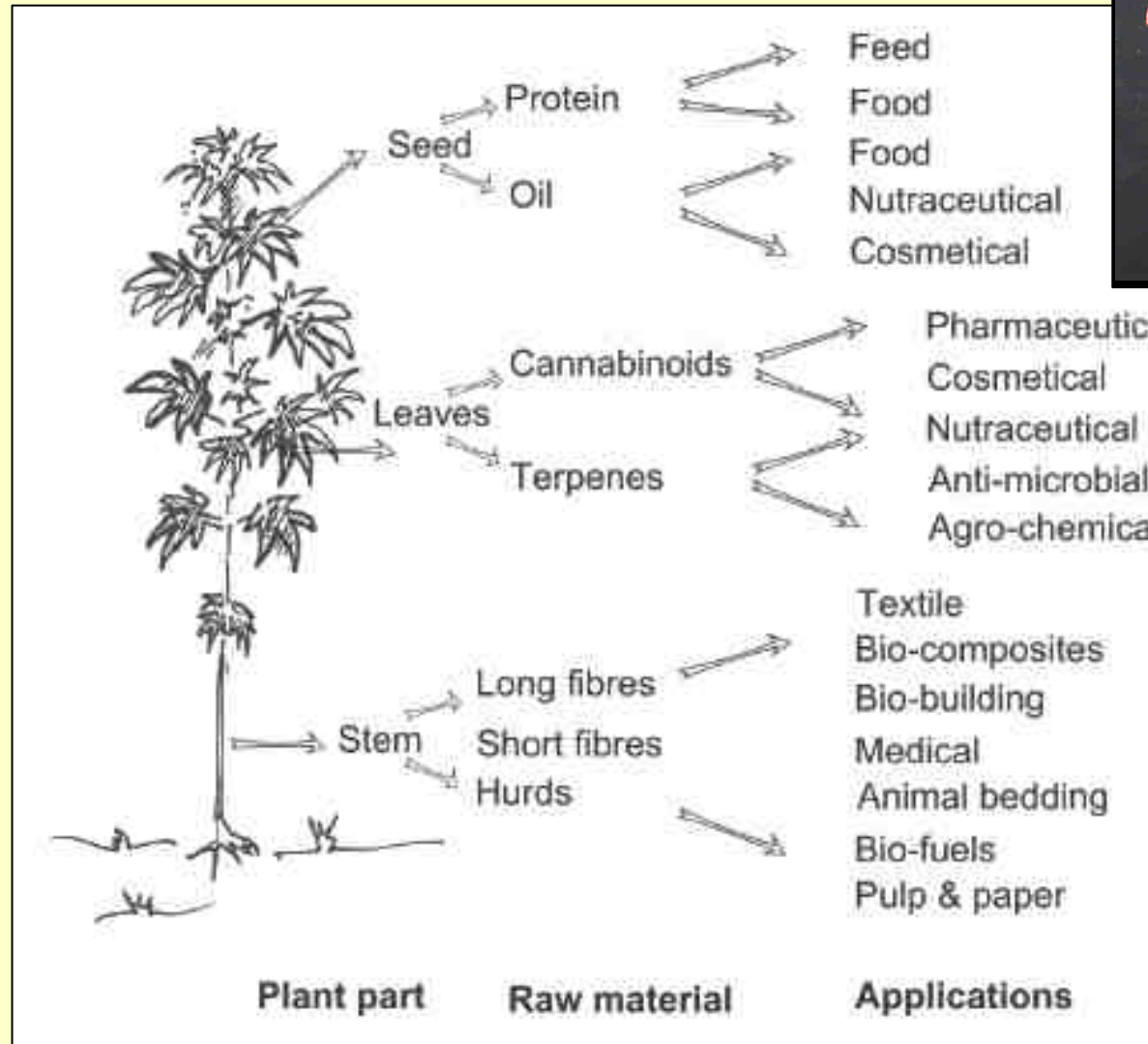

# La filiera non-medicinale

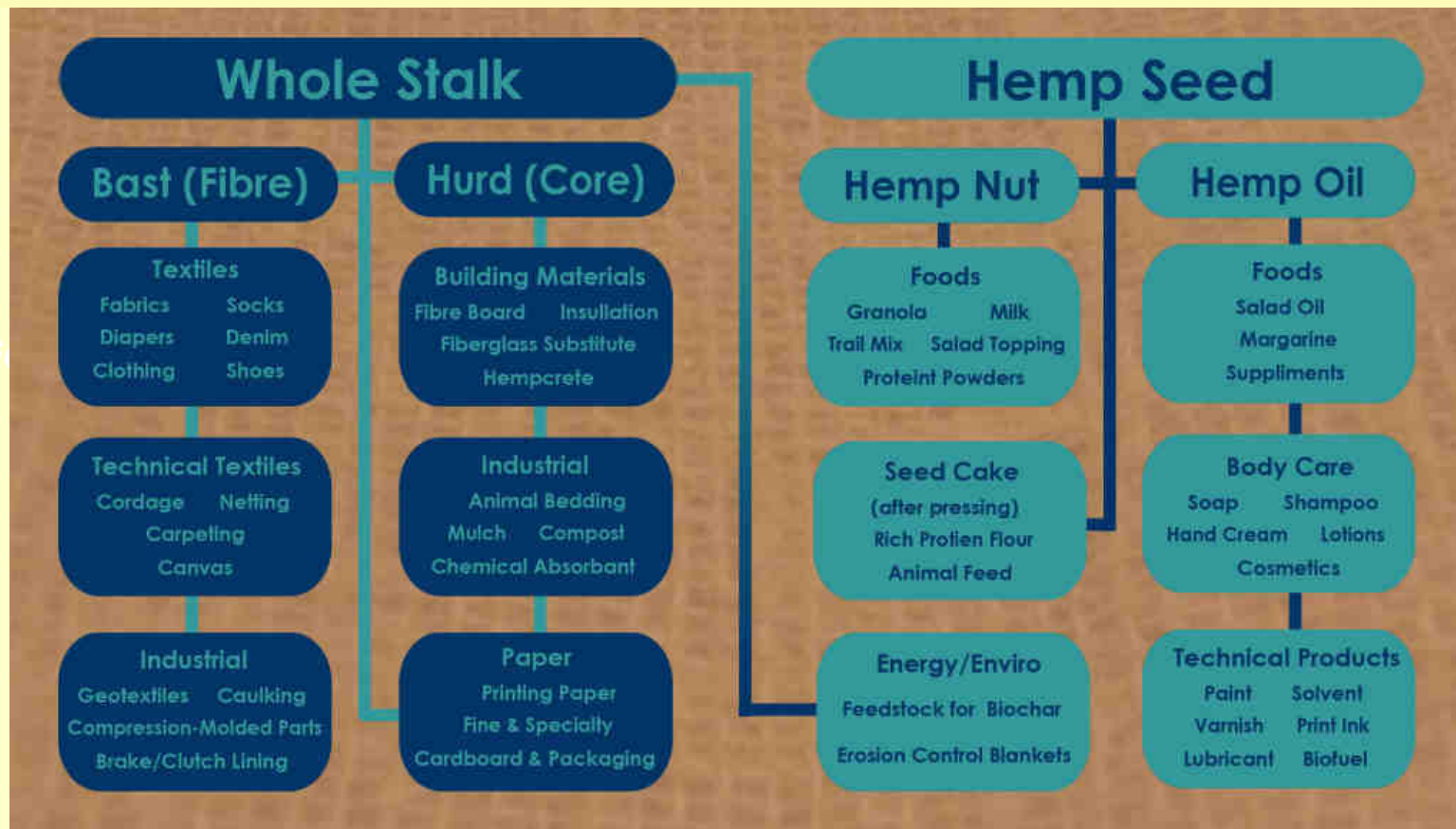

# *Come ci sono tanti peperoncini, cosl' ci sono tante canape*



# Relazioni biogenetiche dei fitocannabinoidi

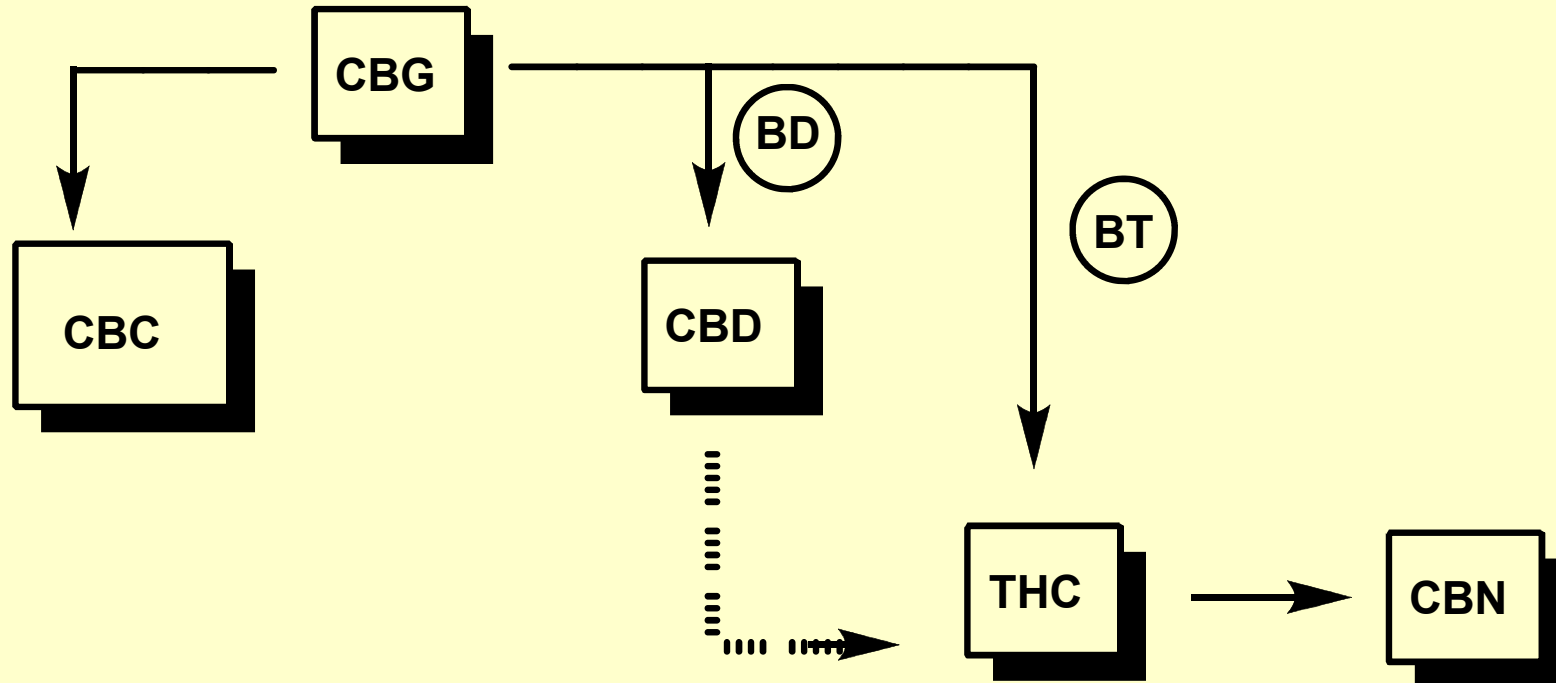

- La ciclizzazione di GBG a CBD o THC dipende da isoforme diverse di uno stesso enzima, corrispondenti a due alleli, B<sub>D</sub> e B<sub>T</sub>.
- La frequenza dei due alleli porta a piante che contengono prevalentemente CBD, THC od una miscela dei due composti



## *Canape diverse hanno profilo fitochimico diverso*

<b>Tipo di canaèa</b>	<b>Pare usata</b>	<b>Profilo fitochimico</b>
<b>Canapa da fibra</b>	<b>Fusto</b>	<b>CBD &gt;&gt; THC</b>
<b>Canapa alimentare</b>	<b>Semi</b>	<b>-----</b>
<b>Canapa medicinale</b>	<b>Infiorescenze femminili</b>	<b>THC, CBD.....</b>
<b>Canapa ricreazionale</b>	<b>Infiorescenze femminili</b>	<b>THC &gt;&gt; CBD</b>



## *La canapa industriale (da fibra)*



## *La canapa come risorsa strategica*



# La canapa cartiaria

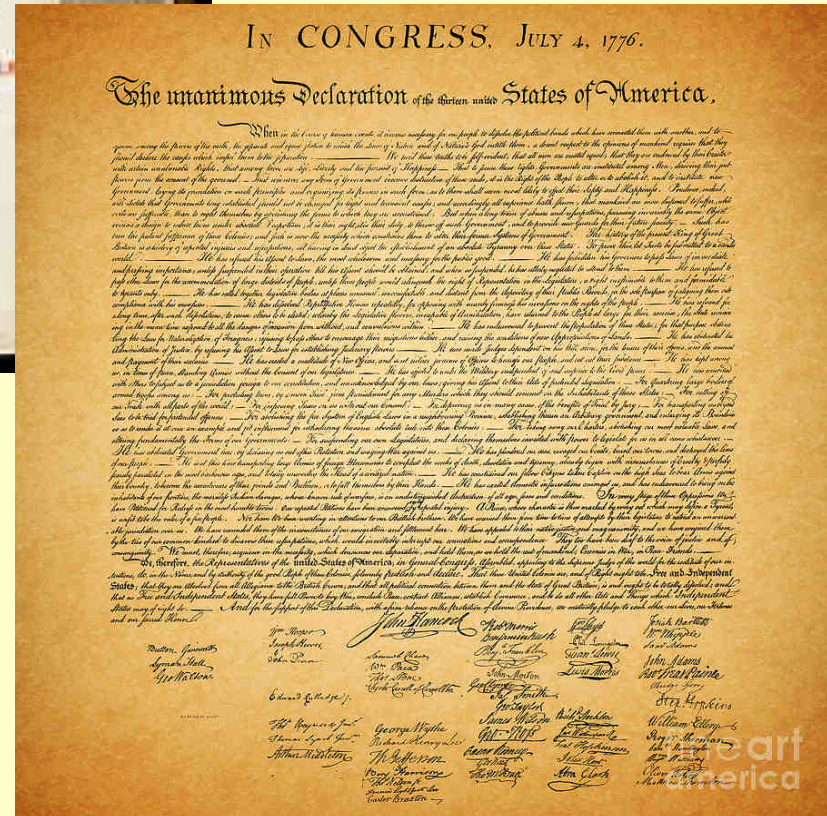

# La canapa tessile

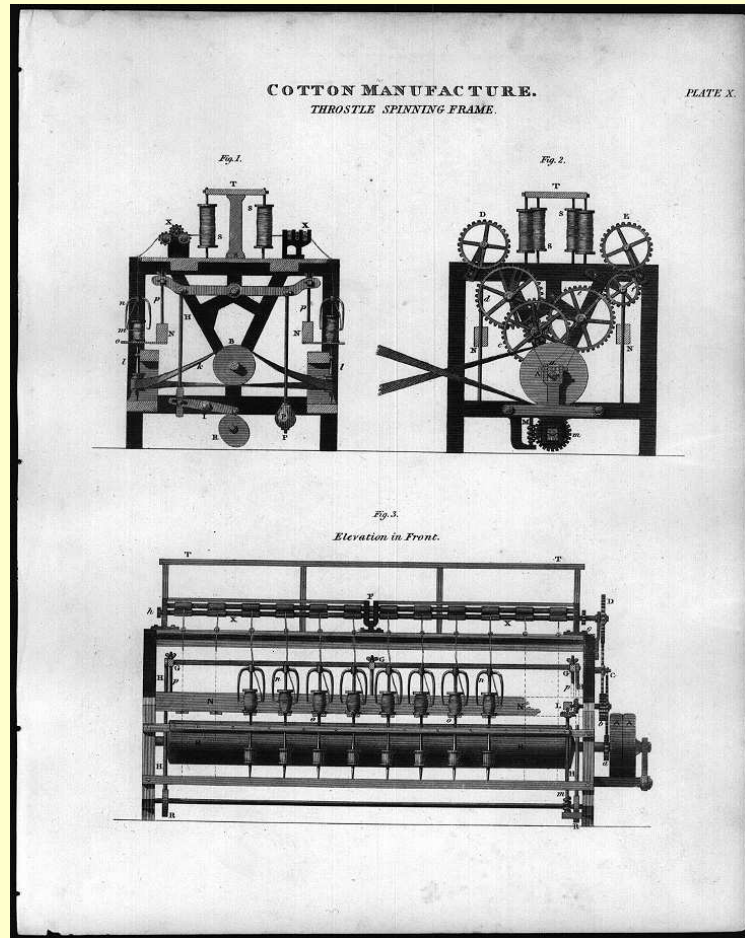

# *La canapa nella storia*

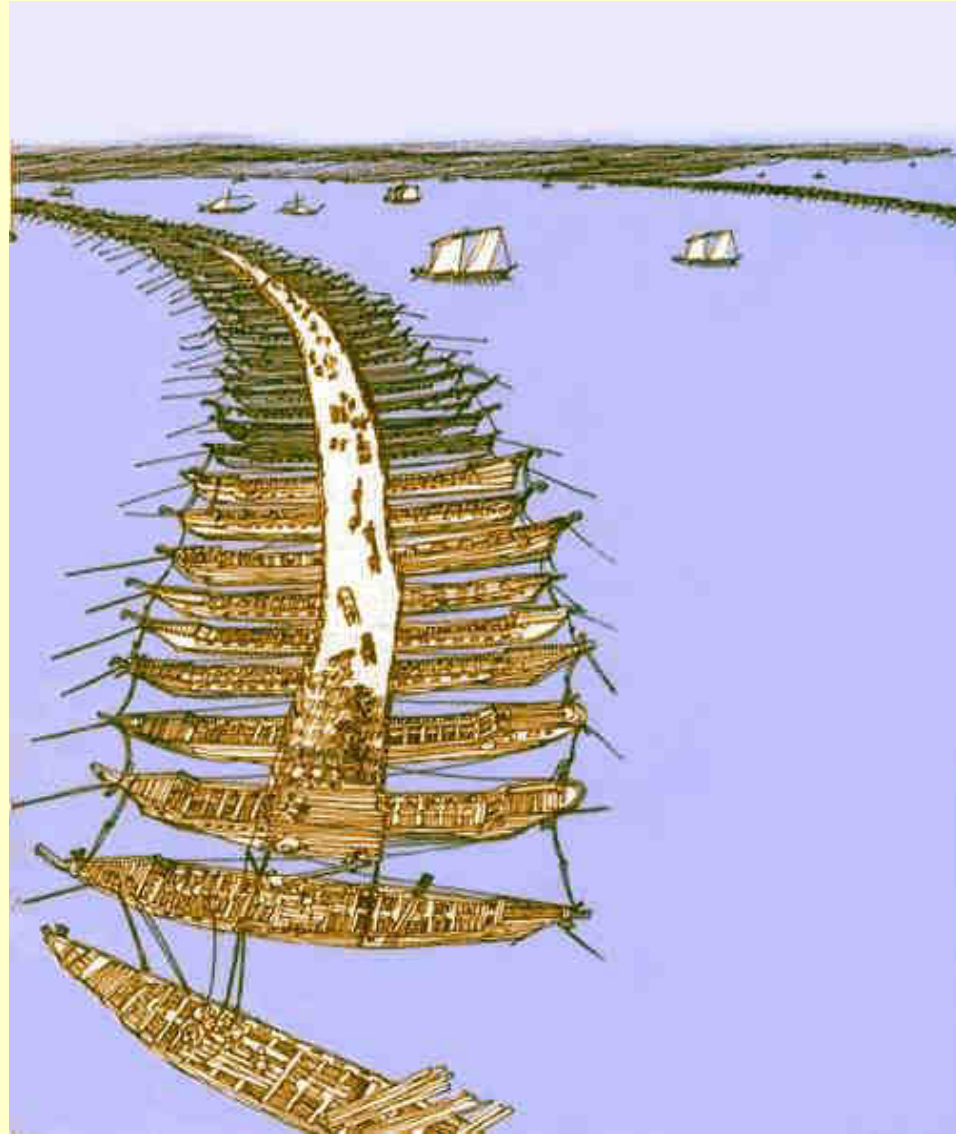

# *La canapa nella storia*

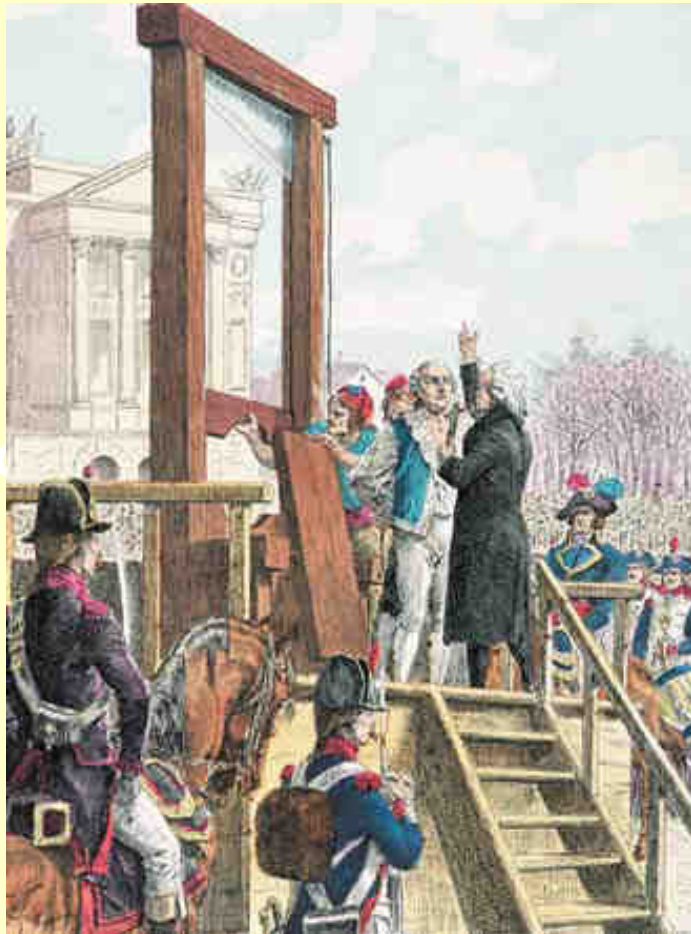

## *Fu la canapa a sconfiggere Napoleone?*





## La canapa alimentare



N  
Gene



# *Buddah e i semi di canapa*

NUCLEUS

*Gene Promoter*



## *Una dieta sbilanciata in termini di acidi grassi essenziali*

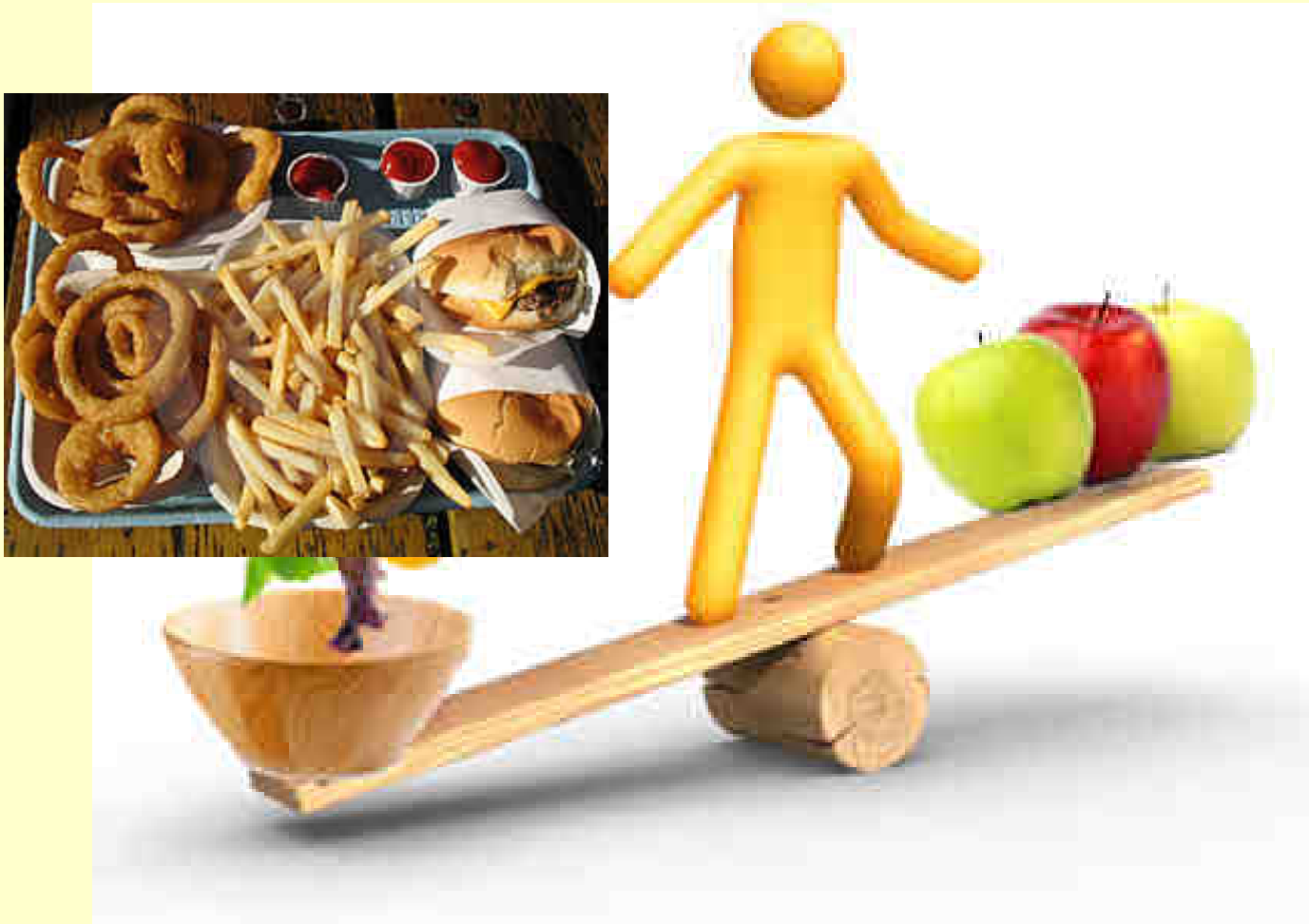

## Rapporto fra omega 6 e omega 3 nella dieta

**1840 : circa 6:4**

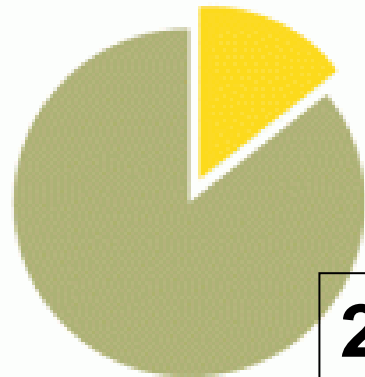
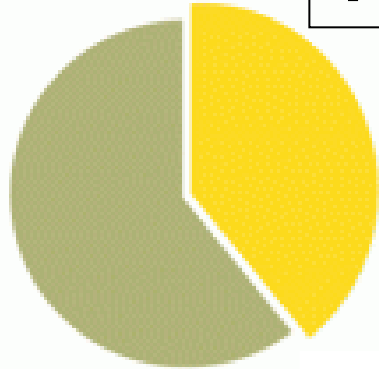

OMEGA-3

OMEGA-6

**2012: circa 15-**

**1**

# La nostra dieta è pro-infiammatoria

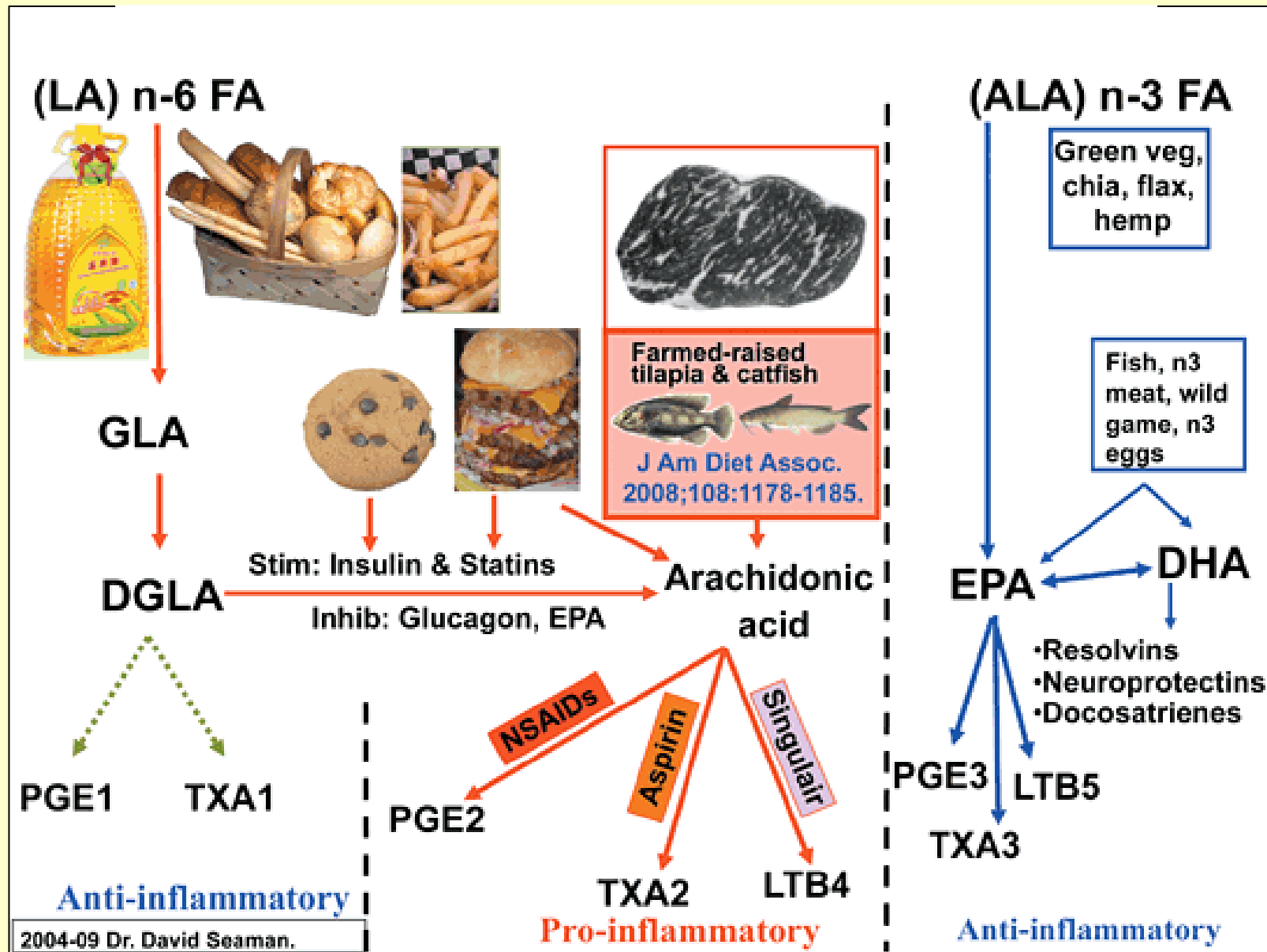

# Una via dietetica alla visione IR?

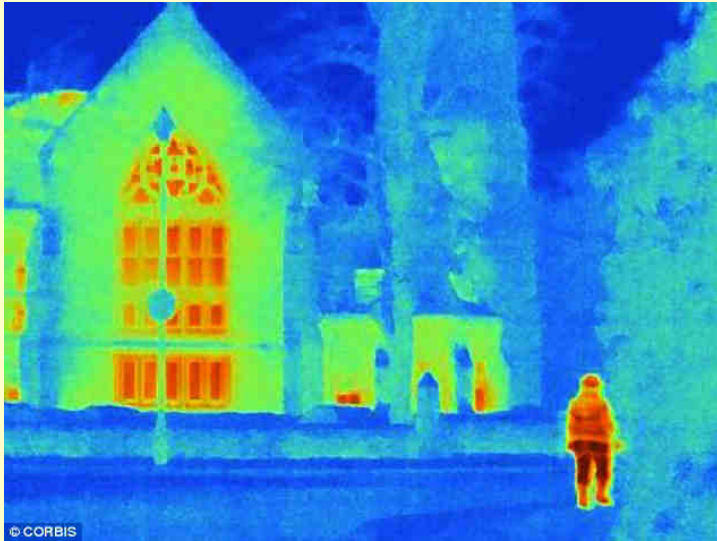

*Gene Promoter*

